



SERIES 764100

LOW TEMPERATURE CARBON STEEL

Carbon steel, ANSI class 600 flanged ends ball valve.

- Full port, sizes 1/2" to 4".
- Temperature up to 366°F.
- Blow out proof stem.
- Metal filled P.T.F.E. seats.
- Space saving design.
- 100% tested.
- FIRE SAFE certified to API 607 6th edition.
- ANSI B16.34 design.
- Antistatic device.

NEW

COMPLIES WITH NACE MR 0175/ISO 15156 AND NACE MR 0103.

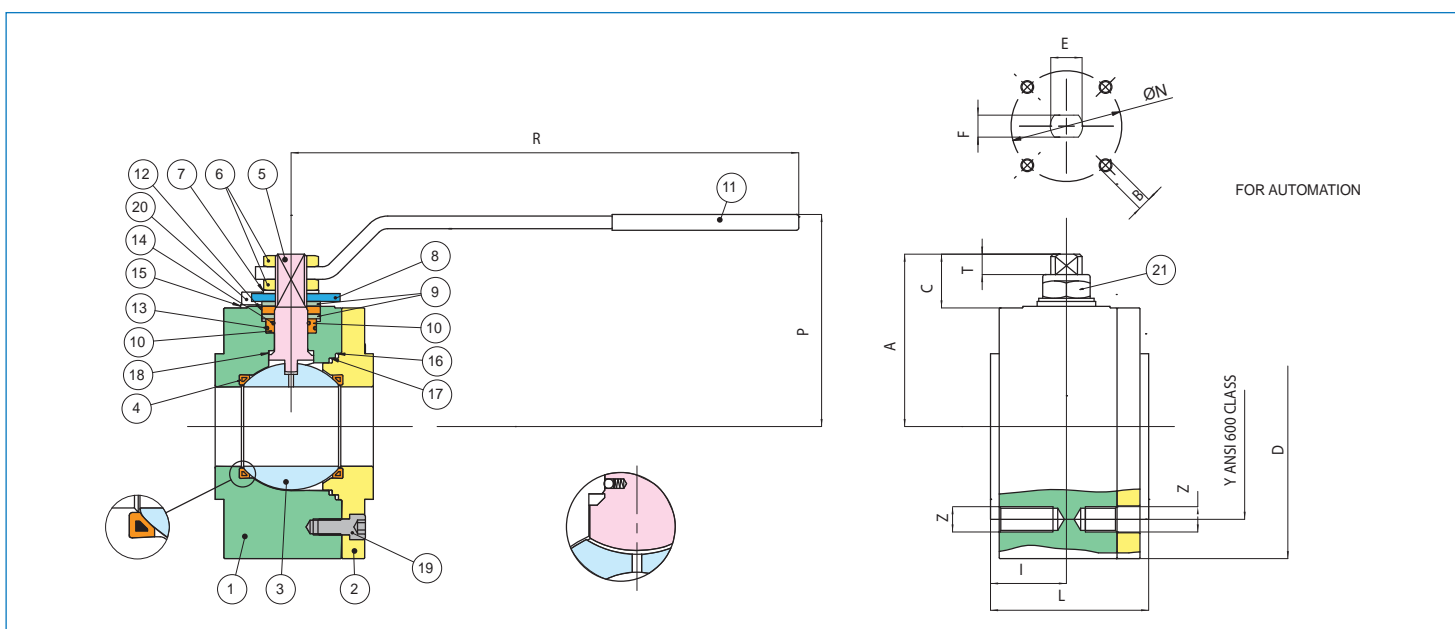

N POS	PART NAME	MATERIAL	N PCS
1	BODY	A350 - LF2	1
2	END CONNECTION	A350 - LF2	1
3	BALL	A276-304/A351-CF8	1
4	BALL SEAT	P.T.F.E. + MET	2
5	STEM	A182 - F304	1
6	NUT	CARBON STEEL	1
7	SPRING WASHER	CARBON STEEL	1
8	90° STOP	CARBON STEEL	1
9	BUSH	A276-316	1
10	STEM SEAL	P.T.F.E.	1
11	HANDLE	CARBON STEEL	2
12	STEM SEAL	GRAPHOIL	2
13	RING	FKM (VITON)	1
14	RING	FKM (VITON)	1
15	WASHER	A276-304	2
16	BODY SEAL	GRAPHOIL	1
17	BODY SEAL	P.T.F.E.	1
18	THRUST WASHER	P.T.F.E.	1
19	SCREW	CARBON STEEL	1
20	SCREW	STAINLESS STEEL	1
21	NUT	STAINLESS STEEL	1

SIZE	D	Y	Z	I	L	R	P	A	C	T	E	F	ØN	B	Cv	Lbs
1/2"	3.74	2.63	4xM14	0.93	2.17	5.16	2.80	2.07	0.69	0.30	M10	0.28	1.65-F04	M5	18.95	5.29
3/4"	4.53	3.25	4xM16	0.94	2.36	6.85	3.46	2.66	0.89	0.40	M12	0.31	1.65-F04	M5	34.30	8.38
1"	4.92	3.50	4xM16	1.04	2.56	6.85	3.62	2.85	0.93	0.43	M12	0.31	1.65-F04	M5	50.00	10.58
1 1/2"	6.10	4.50	4xM20	1.50	3.35	9.88	5.16	4.21	1.26	0.48	M16	0.39	1.97-F05	M6	267.44	24.68
2"	6.50	5.00	8xM16	1.89	3.94	12.64	5.28	4.29	1.34	0.51	M20	0.55	2.76-F07	M8	308.14	30.86
3"	8.27	6.63	8xM20	2.95	5.91	15.00	6.10	5.20	1.71	0.63	M24	0.71	2.76-F07	M8	1015.12	70.53
4"	10.83	8.50	8xM24	3.64	7.28	15.00	7.28	6.50	1.71	0.75	M24	0.71	4.02-F10	M10	1616.28	154.28

