

• NOMINAL VALUES:

- Pressure rating max 115 PSI
- Temperature range: standard (-4°F; +185°F), high (-4°F; +302°F), low (-40°F; +185°F)
- Pre lubricated for life of actuator on assembly
- Fully tested on manufacture 100%

• ROTATION ADJUSTMENT 0-90°:

- From MOD. 52 up to 140
 - standard $\pm 5^\circ$ in both clockwise and counterclockwise direction by means of adjusting screws outside the internal air supply chambers
 - adjusting cam with plane faces for manual intervention
 - standard optic position indicators
- MOD. 160-200-270
 - standard $\pm 5^\circ$ in counterclockwise direction by means of adjusting screws in the caps
 - kit for $\pm 5^\circ$ in clockwise direction available on request

1 • DIE CAST ALUMINIUM END CAPS:

- Standard polyester powder coated
- Upon request nickel - plated for corrosive environments

2 • CONCENTRING SPRING SETS:

- Standard treatment phosphated
- High resistance and reliability
- Spring sets to suit different air pressure/torque requirements
- Long securing screws to allow safe dismantling for maintenance
- Same body dimensions for DA/SR versions

3 • ASSEMBLING SCREW:

- Stainless steel as standard

• EXTERNAL CONNECTION:

- Top of pinion according to Namur norm
- Solenoid valve connection according to Namur norm
- Bottom of pinion according to ISO 5211-DIN 3337

4 • PINION MADE IN STEEL:

- Nickel-plated for standard version against internal and external corrosion
- Stainless steel for corrosive environments
- Anti-blow out design

5 • BODY MANUFACTURED FROM EXTRUDED ALUMINIUM UNI 6060:

- Hard-coat anodized as standard finish 45-50 (micron)
- Good wear resistance
- High corrosion resistance
- Special finishes nickel-plating or epoxy coated
- Bore finished to high standard to ensure low friction and long life

6 • PISTON GUIDES IN POM:

- Large contact area
- Low friction for self lubricating material
- Long life

7 • SEALS:

- NBR standard version
- Viton high temperature version
- SILICON low temperature version

8 • PISTONS MADE FROM DIE CAST ALUMINIUM:

- Chemical nickel plating upon request

• TWIN RACK AND PINION DESIGN:

- Constant torque output
- Compact design
- Balanced internal forces
- Robust design to ensure long life

ANTI-BLOWOUT SYSTEM

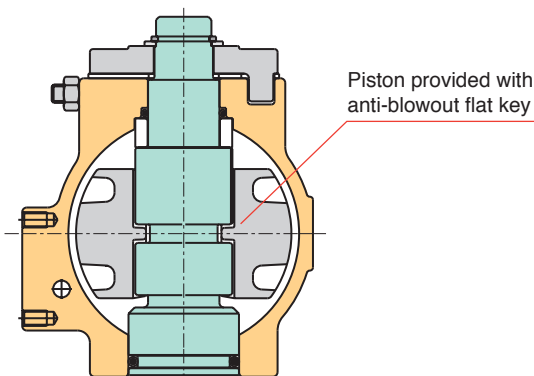

MOUNTING VARIATIONS

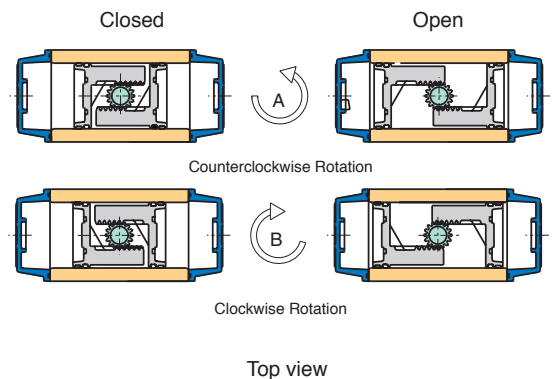

ACTUATOR PARTS

MOD. 32

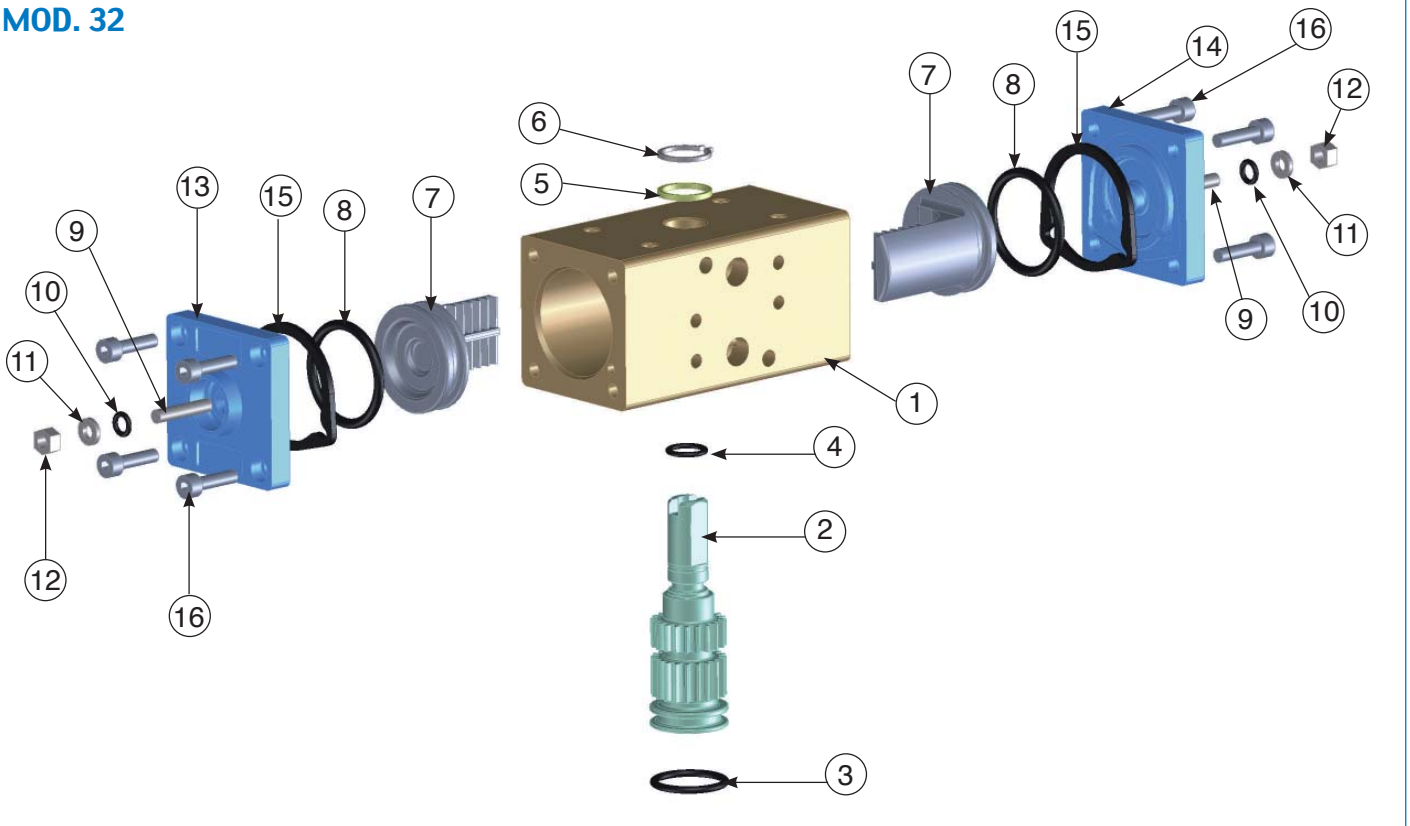

ITEM	DESCRIPTION	MATERIAL	TREATMENT	Q.TY
1	Body	Extruded aluminium	Hard anodized	1
2	Anti-blowout pinion	Steel	Nickel plated	1
• 3	Lower pinion o-ring	NBR		1
• 4	Top pinion o-ring	NBR		1
• 5	Spacer ring	POM		1
6	Pinion snap ring	Steel	Nickel plated	1
7	Piston	Die cast aluminium		2
• 8	Piston o-ring	NBR		2
9	Stop bolt	Stainless steel		2
• 10	Stop bolt o-ring	NBR		2
11	Washer	Stainless steel		2
12	Stop bolt retaining nut	Stainless steel		2
13	Left end cap	Die cast aluminium	Painted	1
14	Right end cap	Die cast aluminium	Painted	1
15	End cap seats	NBR		2
16	End cap fixing screw	Stainless steel		8

• Parts subject to wear

MOD. FROM 52 TO 140

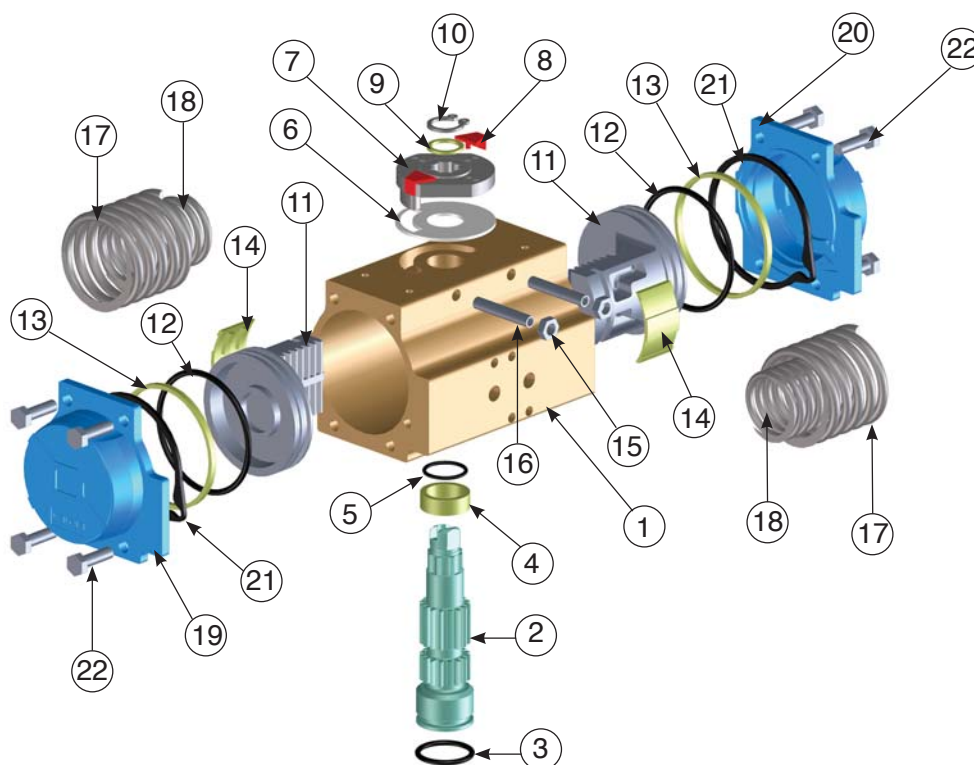

ITEM	DESCRIPTION	MATERIAL	TREATMENT	Q.TY DA	Q.TY SR
1	Body	Extruded aluminium	Hard anodized	1	1
2	Anti-blowout pinion	Steel	Nickel plated	1	1
• 3	Lower pinion o-ring	NBR		1	1
• 4	Pinion spacer ring	POM		1	1
• 5	Top pinion o-ring	NBR		1	1
• 6	Cam spacer ring	POM		1	1
7	Cam	Stainless steel		1	1
8	Position indicator	Nylon		2	2
9	Pinion washer	Stainless steel		1	1
** 10	Pinion snap ring	Steel	Nickel plated	1	1
11	Piston	Die cast aluminium		2	2
• 12	Piston o-ring	NBR		2	2
• 13	Antifriction ring	POM		2	2
• 14	Piston thrust block	POM		2	2
15	Stop bolt retaining nut	Stainless steel		2	2
16	Stop bolt	Stainless steel		2	2
17	External spring	Steel	Zinc-phosphate	0	See spring setting at page 65
18	Internal spring	Steel	Zinc-phosphate	0	
19	Left end cap	Die cast aluminium	Painted	1	1
20	Right end cap	Die cast aluminium	Painted	1	1
21	End cap seats	NBR		2	2
22	End cap fixing screw	Stainless steel		8	8

• Parts subject to wear ** Reinforced series DIN 471 - UNI 7436

ACTUATOR PARTS

MOD. FROM 160 – 200 – 270

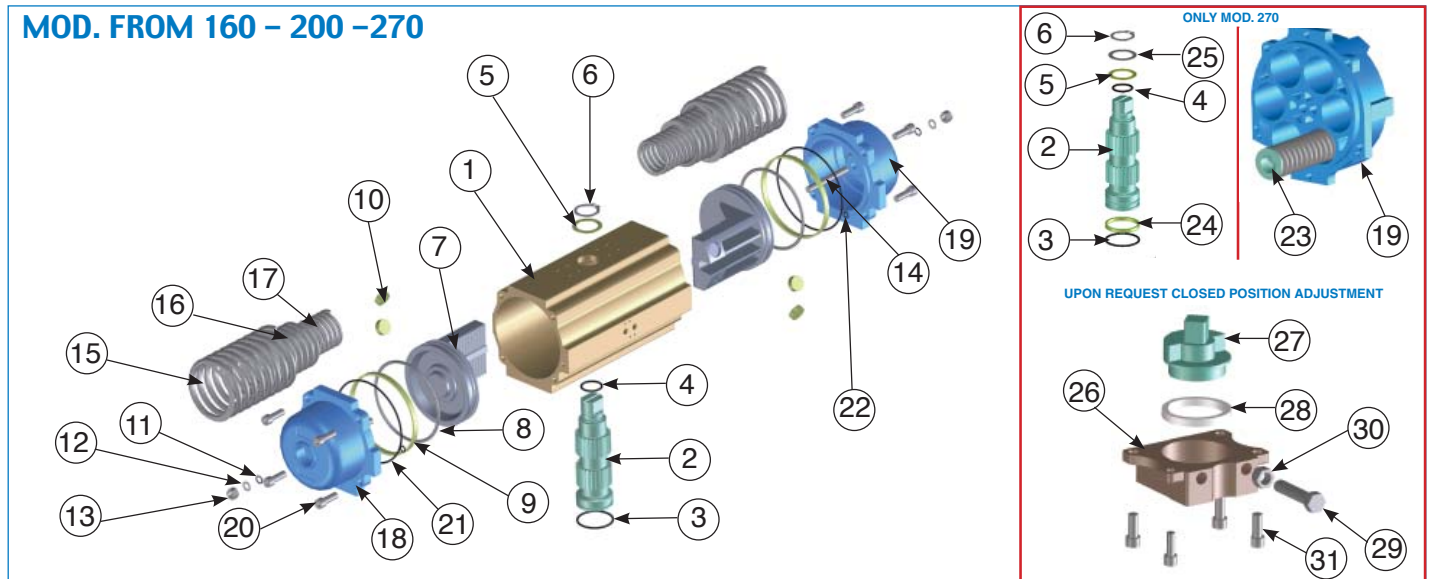

ITEM	DESCRIPTION	MATERIAL	TREATMENT	Q.TY DA	Q.TY SR
1	Body	Extruded aluminium	Hard anodized	1	1
2	Anti-blowout pinion	Steel	Nickel plated	1	1
• 3	Lower pinion o-ring	NBR		1	1
• 4	Top pinion o-ring	NBR		1	1
• 5	Pinion spacer ring	POM		1	1
6	Pinion snap ring	Steel	Nickel plated	1	1
7	Piston	Die cast aluminium		2	2
• 8	Piston o-ring	NBR		2	2
• 9	Antifriction ring	PTFE 15% graphite		2	2
• 10	Piston thrust block	POM		4 6	4 6
• 11	Stop bolt o-ring	NBR		2	2
12	Washer	Stainless steel		2	2
13	Stop bolt retaining nut	Stainless steel		2	2
14	Stop bolt	Stainless steel		2	2
15	External spring	Steel	Zinc-phosphate	0	See spring setting at page 65
16	Central spring	Steel	Zinc-phosphate	0	
17	Internal spring	Steel	Zinc-phosphate	0	
18	Left end cap	Die cast aluminium	Painted	1	1
19	Right end cap	Die cast aluminium	Painted	1	1
20	End cap fixing screw	Stainless steel		8 12	8 12
21	End cap o-ring	NBR		2	2
22	End cap fixing screw	NBR		2	2
23 ***	Precompressed spring	Steel	Zinc-phosphate	0	See spring setting at page 65
24 ***	Antifriction ring	PTFE 15% graphite		1	1
• 25 ***	Pinion washer	Stainless steel		1	1
UPON REQUEST CLOSED POSITION ADJUSTMENT					
26	Plate	GGG40	Painted	1	1
27	Coupling	Steel	Nickel plated	1	1
• 28	Antifriction ring	PTFE		1	1
29	Stop screw	Steel	Zinc plated	1	1
30	Stop bolt retaining nut	Stainless steel		1	1
31	Fixing screws	Stainless steel		4	4

* Parts subject to wear 6 12 *** Valid for mod. 270 only

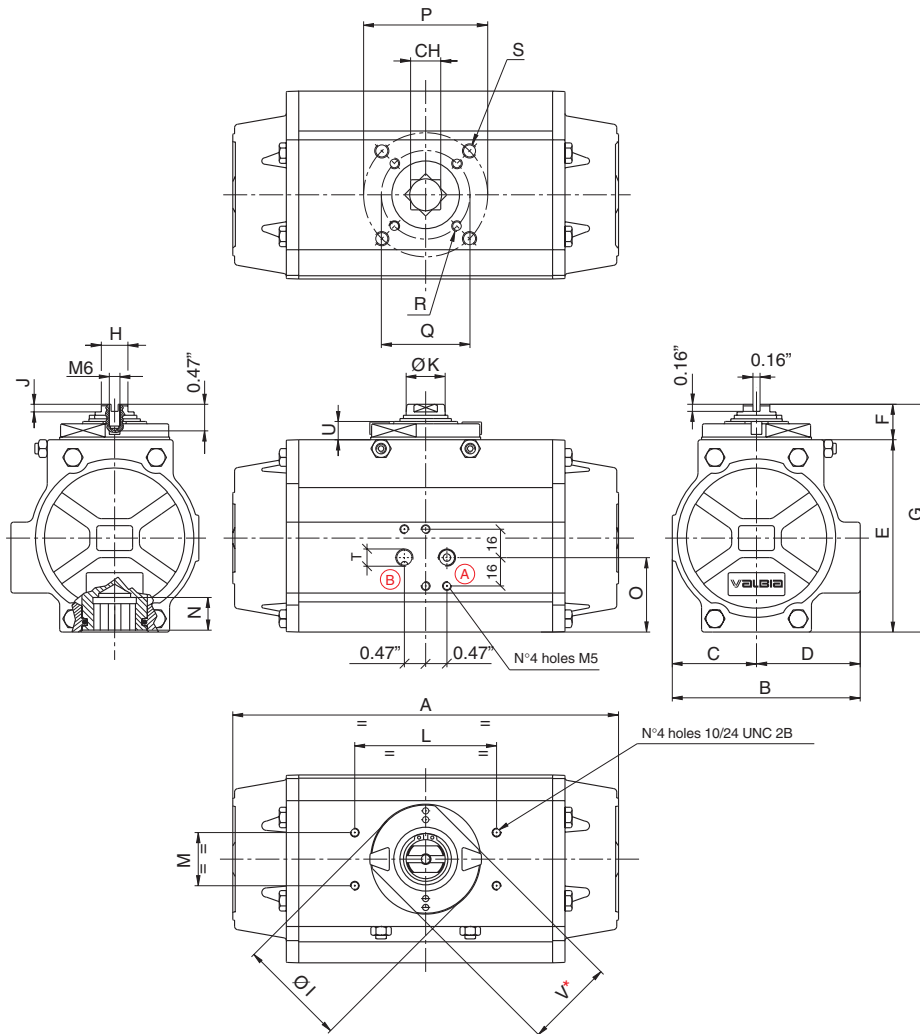

* For mod. from 52 to 100

** Upon request F04

(A) CCW rotation

(B) CW rotation

MOD.	DRILLING ISO 5211	CH	A	B	C	D	E	F	G	H	ØI	J	ØK	L	M	N	O	P	Q	R	S	T NPT	U	V
52	F03 - F05	0.43	5.49	2.80	1.18	1.61	2.74	0.79	3.52	0.35	1.65	0.24	0.47	3.15	1.18	0.47	1.04	1.97	1.42	10-24 UNC 2BX0.29"	1/4-20 UNC 2BX0.35"	1/8"	0.35	1.50
63	F05 - F07	0.55	6.38	3.17	1.40	1.77	3.17	0.79	3.96	0.43	1.89	0.24	0.59	3.15	1.18	0.63	1.08	2.76	1.97	1/4-20 UNC 2BX0.31"	5/16-18 UNC 2BX0.47"	1/8"	0.35	1.61
75	F05 - F07	0.67	8.15	3.72	1.65	2.07	3.82	0.79	4.61	0.51	2.40	0.18	0.75	3.15	1.18	0.75	1.38	2.76	1.97	1/4-20 UNC 2BX0.31"	5/16-18 UNC 2BX0.47"	1/8"	0.41	1.97
85	F05 - F07	0.67	9.35	4.17	1.87	2.30	4.27	0.79	5.06	0.59	2.40	0.18	0.87	3.15	1.18	0.75	1.65	2.76	1.97	1/4-20 UNC 2BX0.31"	5/16-18 UNC 2BX0.47"	1/8"	0.41	1.97
100	F07 - F10	0.67	10.69	4.84	2.17	2.68	4.78	0.79	5.57	0.59	2.40	0.18	0.87	3.15	1.18	0.81	1.97	4.02	2.76	5/16-18 UNC 2BX0.31"	3/8-16 UNC 2BX0.55"	1/4"	0.41	1.97
115	F07 - F10	0.87	12.91	5.39	2.52	2.87	5.57	1.18	6.75	0.87	3.31	0.30	1.26	5.12	1.18	0.94	1.97	4.02	2.76	5/16-18 UNC 2BX0.47"	3/8-16 UNC 2BX0.59"	1/4"	0.63	-
125	F07 - F10	0.87	14.41	5.83	2.68	3.15	6.04	1.18	7.22	0.87	3.31	0.30	1.26	5.12	1.18	0.94	2.40	4.02	2.76	5/16-18 UNC 2BX0.47"	3/8-16 UNC 2BX0.59"	1/4"	0.63	-
140	F10 - F12	1.06	16.85	6.46	3.01	3.44	6.93	1.18	8.11	0.94	3.46	0.28	1.38	5.12	1.18	1.14	2.80	4.92	4.02	3/8-16 UNC 2BX0.59"	1/2-13UNC 2BX0.71"	1/4"	0.63	-

DIMENSIONS MOD.32 – 160 – 200 – 270

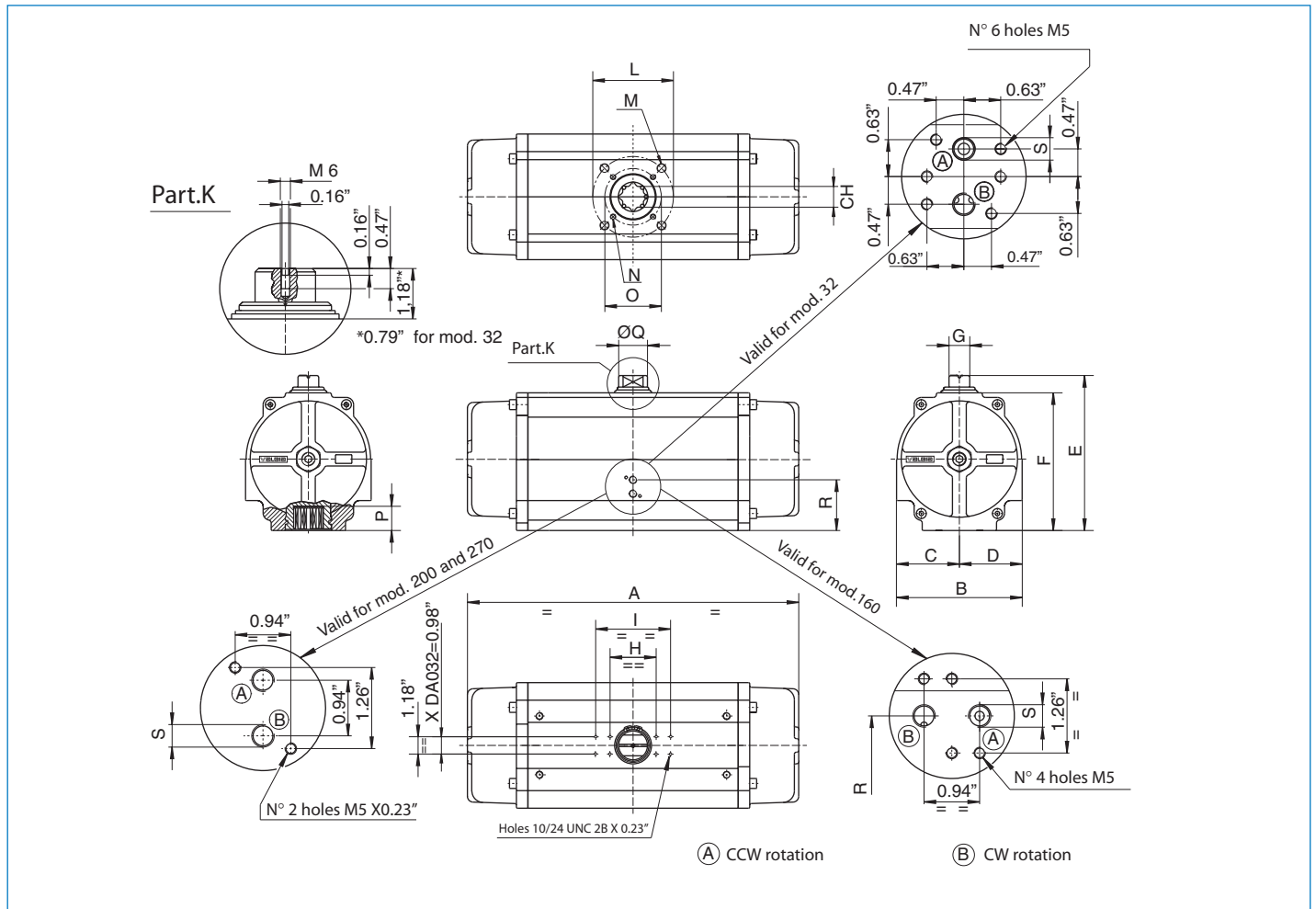

MOD.	DRILLING ISO 5211	CH	A	B	C	D	E	F	G	H	I	L	M	N	O	P	ØQ	R	S NPT	T	U	V	W
32	F03	0.35	4.33	1.77	0.89	0.89	2.56	1.77	0.39	1.97	-	1.42	10-24 UNC 2BX0.29"	-	-	0.47	0.46	-	1/8"	-	-	-	-
160	F10 - F12	1.06	20.55	7.36	3.43	3.94	8.58	7.40	1.18	3.15	5.12	4.92	1/2-13 UNC 2BX0.71"	3/8-16 UNC 2BX0.59"	4.02	1.26	1.38	3.21	1/4"	6.30	1.77	2.20	2.50
200	F14	1.42	22.64	8.58	4.29	4.29	10.59	9.41	1.42	3.15	5.12	5.51	5/8-11 UNC 2BX0.98"	-	-	1.54	1.97	3.46	1/4"	7.48	2.03	2.52	3.11
270	F16	1.81	26.46	11.42	5.71	5.71	14.21	13.03	1.42	3.15	5.12	6.50	3/4-10 UNC 2BX1.18"	-	-	2.05	1.97	4.76	1/4"	9.06	2.68	3.11	4.37

** Only with square connection at 45°

ACTUATORS WITH CLOSED POSITION ADJUSTMENT OPTIONAL MOD. 160 - 200 - 270

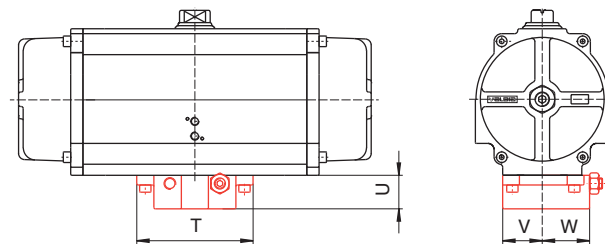

DIMENSIONS MOD.52÷160

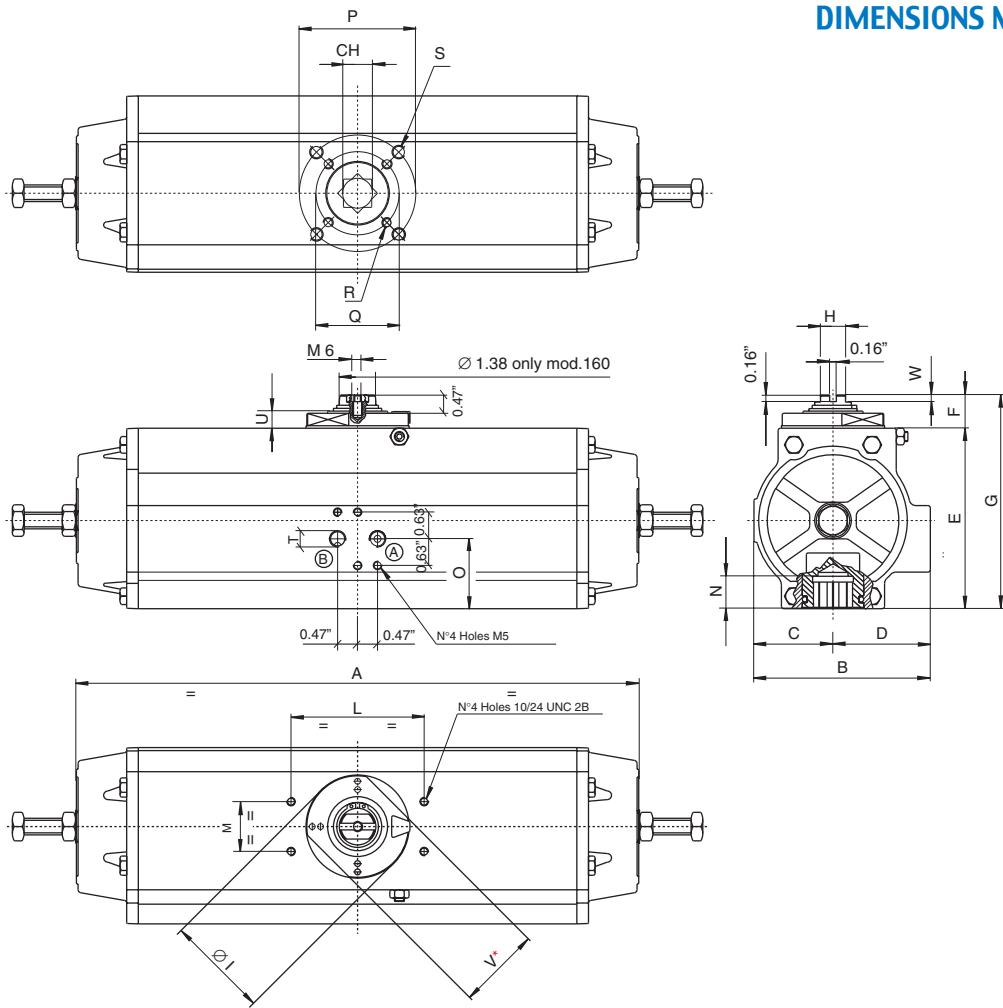

* For mod. From 52 to 100

** Upon request F04 only

(A) CCW rotation

(B) CW Rotation

MOD.	DRILLING ISO 5211	CH	A	B	C	D	E	F	G	H	ØI	L	M	N	O	P	Q	R	S	T NPT	U	V	W
52	F03 - F05**	0.43	7.72	2.80	1.18	1.61	2.74	0.79	3.52	0.35	1.65	3.15	1.18	0.47	1.04	1.97	1.42	10-24 UNC 2BX0.29"	1/4-20 UNC 2BX0.35"	1/8"	0.35	1.50	0.24
63	F05 - F07	0.55	9.09	3.17	1.40	1.77	3.17	0.79	3.96	0.43	1.89	3.15	1.18	0.63	1.08	2.76	1.97	1/4-20 UNC 2BX0.31"	5/16-18 UNC 2BX0.47"	1/8"	0.35	1.61	0.24
75	F05 - F07	0.67	11.61	3.72	1.65	2.07	3.82	0.79	4.61	0.51	2.40	3.15	1.18	0.75	1.38	2.76	1.97	1/4-20 UNC 2BX0.31"	5/16-18 UNC 2BX0.47"	1/8"	0.41	1.97	0.18
85	F05 - F07	0.67	13.31	4.17	1.87	2.30	4.27	0.79	5.06	0.59	2.40	3.15	1.18	0.75	1.65	2.76	1.97	1/4-20 UNC 2BX0.31"	5/16-18 UNC 2BX0.47"	1/8"	0.41	1.97	0.18
100	F07 - F10	0.67	15.12	4.84	2.17	2.68	4.78	0.79	5.57	0.59	2.40	3.15	1.18	0.81	1.97	4.02	2.76	5/16-18 UNC 2BX0.31"	3/8-16 UNC 2BX0.55"	1/4"	0.41	1.97	0.18
115	F07 - F10	0.87	18.58	5.39	2.52	2.87	5.57	1.18	6.75	0.87	3.31	5.12	1.18	0.94	1.97	4.02	2.76	5/16-18 UNC 2BX0.47"	3/8-16 UNC 2BX0.59"	1/4"	0.63	-	0.30
125	F07 - F10	0.87	20.93	5.83	2.68	3.15	6.04	1.18	7.22	0.87	3.31	5.12	1.18	0.94	2.40	4.02	2.76	5/16-18 UNC 2BX0.47"	3/8-16 UNC 2BX0.59"	1/4"	0.63	-	0.30
140	F10 - F12	1.06	23.66	6.46	3.01	3.44	6.93	1.18	8.11	0.94	3.46	5.12	1.18	1.14	2.80	4.92	4.02	3/8-16 UNC 2BX0.59"	1/2-13UNC 2BX0.71"	1/4"	0.63	-	0.28
160***	F10 - F12	1.06	26.22	7.36	3.43	3.94	7.40	1.18	8.58	1.18	-	3.15 5.12	1.18	1.26	3.21	4.92	4.02	3/8-16 UNC 2BX0.59"	1/2-13UNC 2BX0.71"	1/4"	-	-	-

The dimension of the adjustment screws change according to the angle of rotation needed.

*** Upon request closed position adjustment



DOUBLE ACTING ACTUATOR

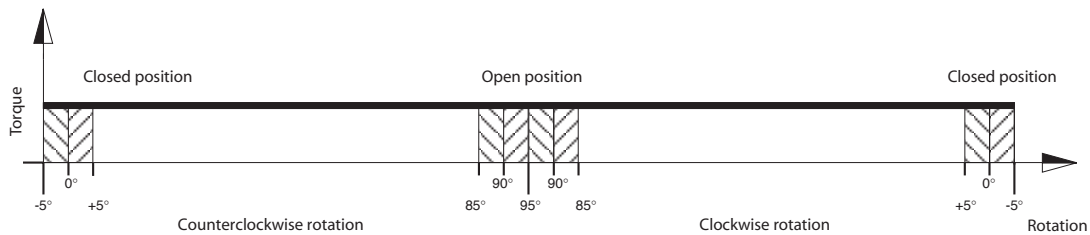
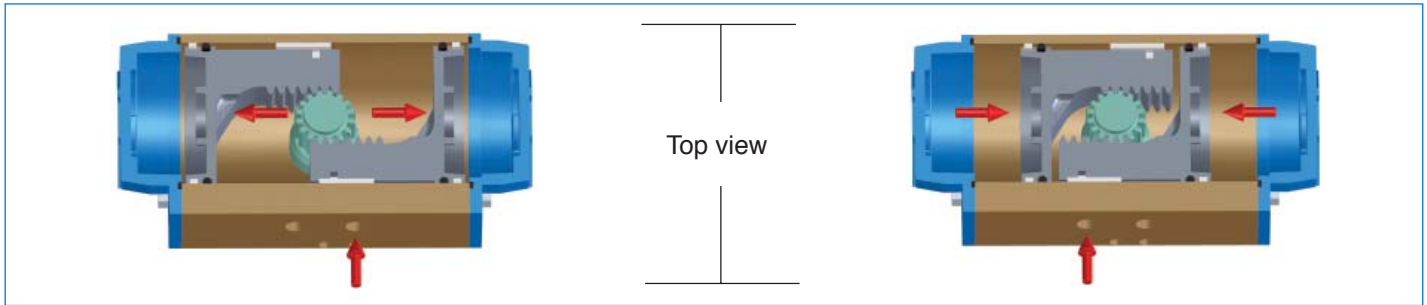

With reference to the above diagram it can be noted that the torque of a double acting actuator remains constant through-out the complete action.

The user can decide on which model to choose according to the own specific requirements, using the following guidelines:

1. Define the maximum torque of the valve to automate.
2. To obtain a safety factor increase the torque value chosen by 25%-50% (subject to the type of valve and working conditions).
3. Once the torque value suggested is obtained consult the torque chart and in relation to the corresponding air pressure find a torque value exact to or exceeding the one obtained.
4. Once the torque value is determined move horizontally to the column "model" to find the actuator model required.

TYPE	AIR SUPPLY PRESSURE (PSI)							
	40	50	60	70	80	90	100	115
	TORQUE OUTPUT DOUBLE ACTING ACTUATORS (in-Lbs)							
DA 32	34	43	55	64	71	82	87	101
DA 52	86	110	133	156	179	203	226	261
DA 63	154	196	238	280	321	363	405	468
DA 75	284	360	435	511	586	661	737	850
DA 85	408	518	629	740	851	962	1072	1238
DA 100	646	818	991	1163	1336	1508	1681	1939
DA 115	1070	1355	1640	1925	2210	2495	2780	3208
DA 125	1409	1783	2157	2532	2906	3280	3654	4216
DA 140	2009	2511	3013	3515	4018	4513	5015	5772
DA 160	2930	3662	4394	5127	5859	6591	7324	8422
DA 200	5488	6866	8239	9612	10981	12359	13732	15792
DA 270	12734	15919	19097	22284	25469	28654	31832	36611

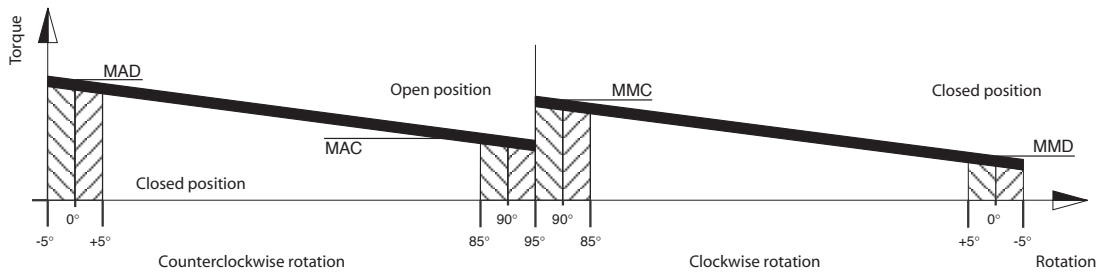
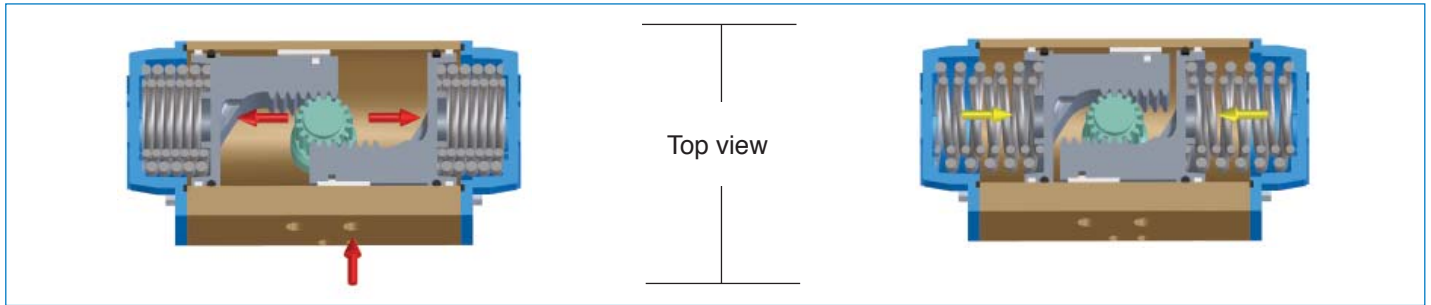

With reference to the above diagram the torque of a spring return actuator is not constant but decreasing. This is due to the action of the springs that when compressed during air actuation counteract the piston movement and accumulate energy which will be available in a decreasing way during the rotation inversion. The torque given by the actuator is defined by four fundamental values.

Opening rotation

MAD = Actuator torque with unfolded springs

MAC = Actuator torque with compressed springs.

Closing rotation

MMC = Torque with compressed springs.

MMD = Torque with unfolded springs

The user can decide on which model to choose according to the own specific requirements, using the following guidelines:

1. Define the maximum torque of the valve to automate.
2. To obtain a safety factor increase the torque value chosen by 25% - 50% (subject to the type of valve and working conditions).
3. Once the torque value suggested is obtained consult the torque chart and in relation to the corresponding air pressure find the torque value exact to or exceeding the one obtained, taking account of the lower value between the MMD and MAC values.
4. Once the torque value is determined move horizontally to the column "model" to find the actuator model required.

VALID FROM MOD. 52 TO MOD. 140

SPRING SETTING

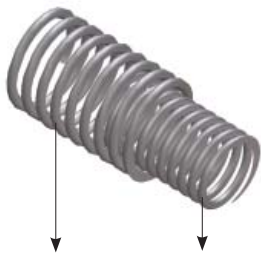

SET	EXTERNAL SPRING	INTERNAL SPRING
01	1	1
02	2	/
03	1	2
04	2	1
05	2	2

VALID FOR MOD. 160 AND 200

SPRING SETTING

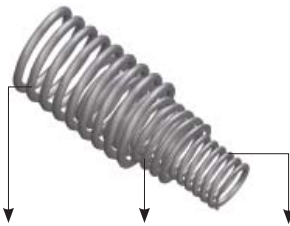

SET	EXTERNAL SPRING	CENTRAL SPRING	INTERNAL SPRING
01	/	2	/
02	2	/	/
03	1	2	/
04	2	/	2
05	2	2	/
06	2	2	2

VALID FOR MOD. 270

SPRING SETTING



PRETENSIONED SPRING

SET	N° OF SPRINGS FOR EACH SIDE
01	2/3
02	3/3
03	3/4
04	4/4
05	4/5
06	5/5
07	5/6
08	6/6

TORQUE OUTPUT SR ACTUATORS

MOD.	SET	SPRING TORQUE (in-Lbs)		AIR SUPPLY PRESSURE (PSI)																
				40		50		60		70		80		90		100		115		
		0° MMD	90° MMC	TORQUE OUTPUT SPRING RETURN ACTUATORS (in-Lbs)																
		0° MAD	90° MAC	0° MAD	90° MAC	0° MAD	90° MAC	0° MAD	90° MAC	0° MAD	90° MAC	0° MAD	90° MAC	0° MAD	90° MAC	0° MAD	90° MAC	0° MAD	90° MAC	
SR52	01	32	44	48	23	72	47	95	70											
	02	42	59			61	31	84	54	108	77									
	03	46	66					80	47	104	70	127	94	150	117					
	04	57	82					70	31	93	55	116	78	140	101	163	125			
	05	72	105							78	32	101	55	125	78	148	102	183	137	
SR63	01	44	85	92	38	134	80	176	122											
	02	58	109			120	56	162	98	204	140									
	03	71	128					149	79	191	121	233	162	275	204					
	04	85	152					136	54	177	96	219	138	261	180	303	222			
	05	111	196							151	53	193	95	235	136	276	178	339	241	
SR75	01	89	172	168	63	244	138	319	214											
	02	118	226			215	85	291	160	366	235									
	03	133	249					275	137	351	212	426	288	502	363					
	04	162	303					247	83	322	158	398	234	473	309	549	385			
	05	205	380						279	81	354	157	430	232	505	308	618	421		
SR85	01	143	242	238	109	349	219	460	330											
	02	176	298			316	163	427	274	537	384									
	03	215	361					387	211	498	322	609	432	720	543					
	04	248	417					354	155	465	265	576	376	687	487	797	633			
	05	321	536						392	146	503	257	614	368	725	478	891	645		
SR100	01	218	395	384	154	556	326	728	499											
	02	288	521			485	199	658	372	830	544									
	03	318	564					628	329	801	502	973	674	1146	847					
	04	389	691					558	203	730	375	903	548	1075	720	1248	893			
	05	489	860						630	206	802	378	975	551	1147	723	1406	982		
SR115	01	363	658	650	270	935	555	1220	840											
	02	449	835			848	378	1133	663	1419	949									
	03	538	957					1044	541	1329	827	1615	1112	1900	1397					
	04	625	1133					958	365	1243	650	1528	935	1813	1220	2098	1505			
	05	800	1432						1067	352	1352	637	1638	922	1923	1207	2350	1635		
SR125	01	470	877	850	328	1224	703	1599	1077											
	02	560	1040			1135		539	1509	914	1883	1288								
	03	718	1313					1351	640	1725	1015	2099	1389	2474	1763					
	04	808	1477					1261	477	1636	851	2010	1226	2384	1600	2758	1974			
	05	1055	1913						1388	415	1762	789	2136	1164	2511	1538	3072	2099		
SR140	01	726	1346	1240	508	1742	1010	2244	1512											
	02	815	1523			1642	821	2144	1323	2646	1825									
	03	1036	1958					1910	856	2412	1358	2914	1861	3408	2355					
	04	1134	2126					1810	668	2312	1170	2814	1672	3308	2166	3810	2668			
	05	1453	2728						1979	515	2481	1017	2975	1511	3477	2013	4233	2769		
SR160	01	885	1345	1921	1390	2644	2140													
	02	1301	1991			2228	1503	2952	2217											
	03	1531	2336			1980	1131	2713	1854	3419	2569									
	04	1770	2841					2447	1350	3162	2074	3886	2779							
	05	2230	3327						2737	1507	3452	2240	4175	2963						
	06	2655	4186								2983	1443	3715	2167	4421	2828	5475	3865		
SR200	01	1540	2168	3718	2904	5069	4317													
	02	2186	3150			4414	3308	5770	4681											
	03	2637	3752			3936	2591	5301	4035	6639	5400									
	04	3124	4699					4788	3080	6126	4445	7486	5795							
	05	3726	5327						5453	3613	6822	5008	8182	6385						
	06	4664	6867								5893	3539	7288	4925	8591	6175	10562	8137		
SR270	01	4469	6973	8574	6017	11883	9317	15309	12743											
	02	5363	8372	7619	4548	10928	7857	14353	11283											
	03	6257	9761	6672	3088	9972	6388	13398	9814	16824	13240									
	04	7150	11159	5716	1619	9016	4928	12442	8353	15877	11779	19177	15080							
	05	8044	12549			8069	3459	11495	6884	14921	10310	18221	13619	21530	16920					
	06	8938	13947					10539	5415	13965	8850	17274	12150	20574	15459					
	07	9832	15336					9584	3955	13009	7381	16319	10681	19619	13990	23053	17416			
	08	10735	16735					8637	2486	12063	5912	15363	9221	18672	12521	22098	15947	27115	20965	

		WORKING TIME (SEC.)													
TYPE	MODEL														
		32	52	63	75	85	100	115	125	140	160	200	270		
ROTAT. 0°-90°	COUNTERCLOCKWISE ROTATION (DA)	CCW	0.03	0.03	0.06	0.12	0.20	0.30	0.53	0.83	0.98	1.15	1.74	4.50	
	CLOCKWISE ROTATION (DA)	CW	0.03	0.04	0.08	0.12	0.19	0.27	0.47	0.66	0.93	1.10	1.70	4.50	
	COUNTERCLOCKWISE ROTATION (SR)	CCW	-	0.09	0.14	0.22	0.31	0.44	0.83	1.08	1.23	1.75	2.38	4.50	
	CLOCKWISE ROTATION (SR)	CW	-	0.09	0.14	0.22	0.33	0.46	0.78	0.90	0.97	1.34	2.19	6.20	
ROTAT. 0°-180°	COUNTERCLOCKWISE ROTATION (DA)	CCW	-	0.05	0.11	0.26	0.30	0.48	0.91	1.94	2.12	2.63	-	-	
	CLOCKWISE ROTATION (DA)	CW	-	0.04	0.13	0.19	0.30	0.49	0.92	1.17	1.45	1.99	-	-	

Approximative times obtained at the pressure of 87 PSI without valve

		WEIGHT CHART (Lbs)											
TYPE	MODEL												
		32	52	63	75	85	100	115	125	140	160	200	270
DA 90°		1.08	2.25	3.26	5.51	7.39	11.02	17.75	22.09	33.86	43.21	70.99	154.00
SR 90°		-	2.62	3.97	6.94	9.37	14.40	23.92	26.76	45.28	65.04	111.00	192.79
DA 180°		-	3.42	5.07	8.53	11.53	17.44	27.34	35.27	47.40	60.63	-	-

		ACTUATOR AIR CONSUMPTION CHART (in cubic inches per stroke)													
TYPE	MODEL														
		32	52	63	75	85	100	115	125	140	160	200	270		
ROTAT. 0°-90°	COUNTERCLOCKWISE ROTATION (DA)	CCW	2.44	6.10	11.60	21.97	31.12	48.21	78.72	99.47	137.91	220.30	347.84	915.36	
	CLOCKWISE ROTATION (DA)	CW	1.83	7.93	14.04	26.85	39.06	61.02	104.35	134.86	192.84	290.47	599.86	1086.22	
	CLOCKWISE ROTATION (SR)	CW	-	6.71	11.60	21.97	32.34	48.82	84.21	108.62	146.46	214.8	462.56	945.87	
ROTAT. 0°-180°	COUNTERCLOCKWISE ROTATION (DA)	CCW	-	10.37	20.14	36.60	54.92	83.60	129.98	176.97	299.02	329.53	-	-	
	CLOCKWISE ROTATION (DA)	CW	-	9.76	17.70	34.17	50.65	80.55	137.30	183.07	237.99	354.55	-	-	